



aeno concept

WINE-MAKING PROCESS DESIGNER & INTEGRATOR

GYROPALETTE® RANGE

The world reference of automated riddling

Quadra Gyropalette®



RIDDLING
CAPACITY :

100 000 to 130 000

standard 75 cl bottle
per year.

STRONG POINTS



Compatible with all
TSR® riddling
containers and boxes.



Modular machine &
compatible with the
Vertical Duo.



The cradles are articulated
at the ends without a
central support.

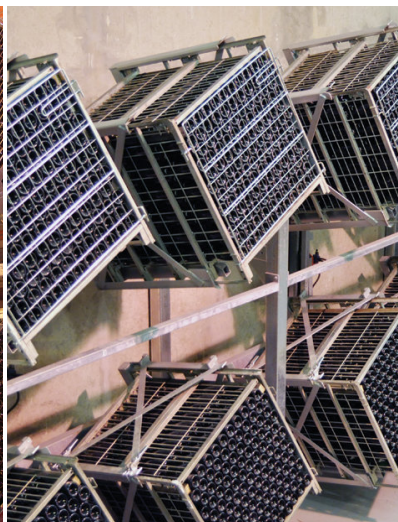
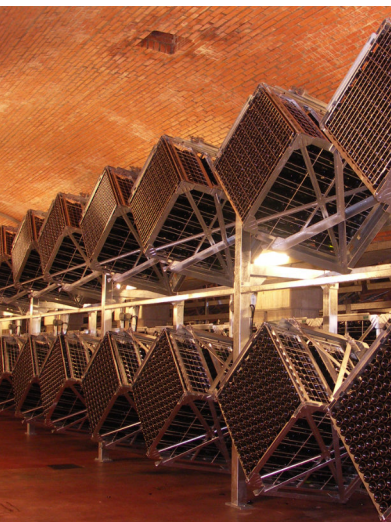

Made in France

CHARACTERISTICS

➔ SOLID

Chassis and cages made of hot galvanised steel, high quality electrical and mechanical components, resistance to cellar humidity, limited maintenance.

➔ PRODUCTIVE

2 cradles with 2 independently rotating cages (per 1/16 turn). 4 cages mounted on 4 large diameter ball bearing supported, orientation crown rotated by 4 sealed electric gear motors.

➔ PRECISION

Inclining to a precise degree by a very robust system, screw-nut motorised system common to the cradles which are linked by small rods.

➔ LOW CONSUMPTION

Very good mechanical efficiency of the rotating and tilting movements : 5 x 0,37 kW motors.

EQUIPMENT OPTIONS



Cages

Choose the cages adapted to your cellar and your process (open, door or automatic cage).



Vibration

The vibration option allows to optimize your riddling cycle with a benefit effect in the evolution of the deposit located in the bottle.



Installation

Possibility to install several Gyropalette® Quadra side by side or back to back.

CONTROL

The riddling controller ACAI V4 allows to drive one or several Gyropalette®.

Available in standard or multigroup

Remote supervision

Exist in coffret or in cabinet shape

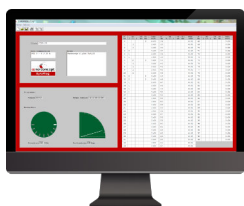

Create your own riddling programs with the Gyroprog® software (Windows® compatible). Once created, transfer the riddling program via a USB dongle in the Gyropalette® controller.



DIMENSIONS

Loading/unloading by forklift with a minimum capacity of 1 600 kg

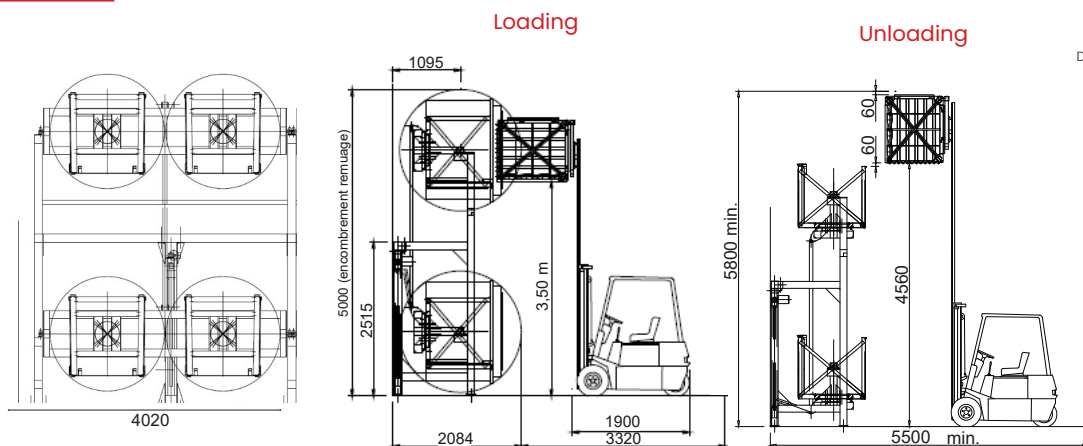

Door cage in level 1 and open cage in level 2
Door cage in level 1 and automatic cage in level 2

DEVICE	3874	3830
Height	3874	3830
Width	4020	4020
Depth	1340	1340
Depth with cage	1584	1524
Depth with box	1882	1782
RIDDLING		
Height	4400	4400
Depth	2200	2200
HANDLING		
Loading height	2800	2800
Loading height + box	3791	3971
Unloading height	2950	3709
Unloading height + box	4300	5209
LAYOUT		
Aisle width	5500	5500